

GRU A TORRE

GA 132

GRU AUTOMATICA CON
MONTAGGIO IDRAULICO

GA compact

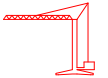

GX



GH city crane



GHS topless



FB F.lli Butti s.r.l.

Via XXV Aprile, 58

23868 Valmadrera (LC) - Italia

Tel. 0341.581108 - Fax 0341.200253

E-mail : fbgru@fbgru.it - <http://www.fbgru.it>



FEM 1.001 - A3
EN 14439 - C25

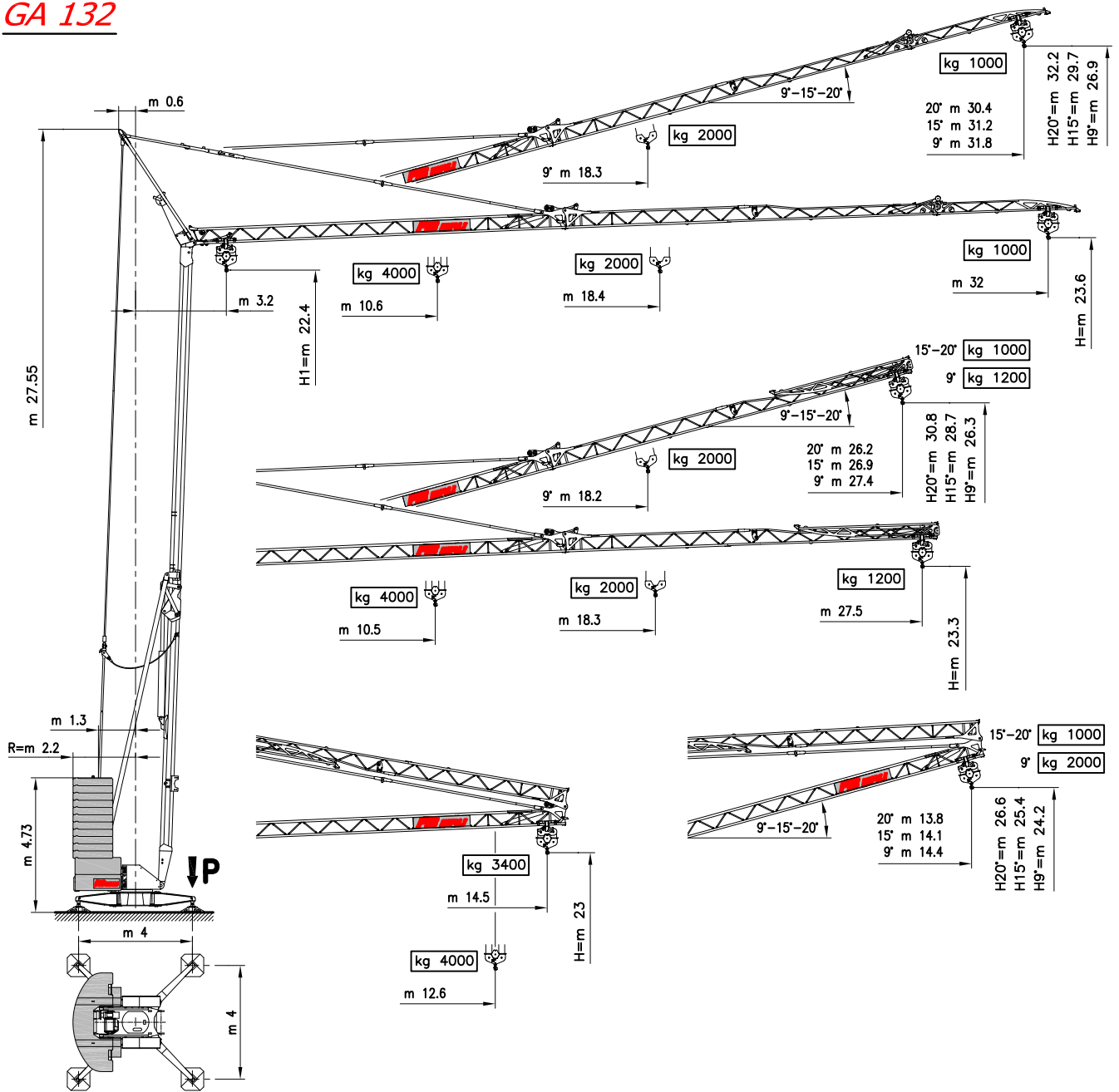

P	
kg 24600	kg 21700
<i>In servizio</i>	<i>Fuori servizio</i>
En servicio	Fuera de servicio
In service	Out of service
In betrieb	Außer betrieb
En service	Hors service

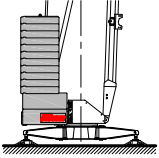
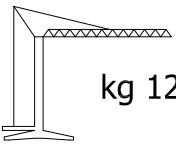
G	
	N° 11x1800 N° 2x1700 N° 2x1920 kg 39620
	 kg 12580

LA GRU LA GRÚA — CRANE
KLAN — GRUE



MOVIMENTO MOVIMIENTO MOVEMENT BEWEGUNG MOUVEMENT	ALIMENTAZIONE ALIMENTACION OPERATING VOLTAGE BETRIEBSSPANNUNG TENSION DE SERVICE	PRESTAZIONI FUNCIONAMIENTOS PERFORMANCES LEISTUNGEN EXÉCUTIONS	
---	---	---	--

SOLLEVAMENTO ELEVACION — HOISTING HEBEN — LEVAGE INVERTER	400 V 50 Hz		1 ^a m/1' - kg	2 ^a m/1' - kg	3 ^a m/1' - kg	4 ^a m/1' - kg	kW 9.2
			5 ↓ ↑	24 ↑ 26 ↓	38 ↑ 40 ↓	45 ↑ 48 ↓	
			2000	2000	1000	600	
			3 ↓ ↑	12 ↑ 13 ↓	19 ↑ 20 ↓	23 ↑ 24 ↓	
			4000	4000	2000	1200	

CARRELLO CARRILLO — JIB TROLLEY LAUFKATZE — DISTRIBUTION INVERTER	400 V 50 Hz	1 ^a m/1'	2 ^a m/1'	3 ^a m/1'	kW 3
		19	42	61	

ROTAZIONE ROTACION — SLEWING DREHEN — ORIENTATION INVERTER	400 V 50 Hz	1 ^a g/1'	2 ^a g/1'	3 ^a g/1'	kW 3
		0 → 0.15	0.15 → 0.45	0.45 → 0.89	



Conforme alle direttive
CEE sul livello acustico
2000/14/CE

Conforme con las directivas
CEE sobre el nivel acustico

In compliance with the EEC
instructions on noise level

Gemäss EWG-Richtlinien für
den Schall-Leistungspegel

Conforme aux directives CEE
sur le niveau acoustique

CURVE DI CARICO

CURVAS DE CARGAS — LOAD DIAGRAMS LASTKURVEN — COURBES DE CHARGES

V32

	m	3	4	5	6	8	10.6	12	14	16	17	18.4	20	22	24	26	28	30	32
	kg	4000							3413	2803	2369	2195	2000	1808	1606	1440	1303	1186	1086

	m	3	4	5	6	8	10	12	14	16	17	18.3	20	22	24	26	28	30	31.8
	kg	2000											1795	1594	1429	1293	1177	1078	1000

	m	3	5	10	15	20	25	30	31.2
	kg	1000							

	m	3	5	10	15	20	25	30.4
	kg	1000						

(0 - 2000 kg) 	(2001 - 4000 kg)
-------------------	----------------------

POTENZA RICHIESTA

POTENCIA-ELECTRICA NECESARIA — NECESSARY ELECTRIC POWER KRAFTBEDARF — PUISSANCE ELECTRIQUE NECESSAIRE

	SOLLEVAMENTO ELEVACION — HOISTING — HEBEN — LEVAGE	kg 2000	kg 4000
	12 kw 400 V - 50 Hz		

TRASPORTO TRANSPORTE — TRANSPORT
TRANSPORT — TRANSPORT

5
km/h

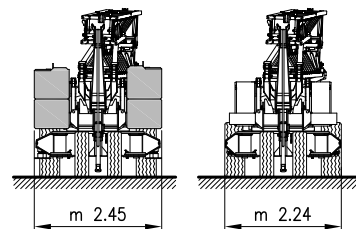
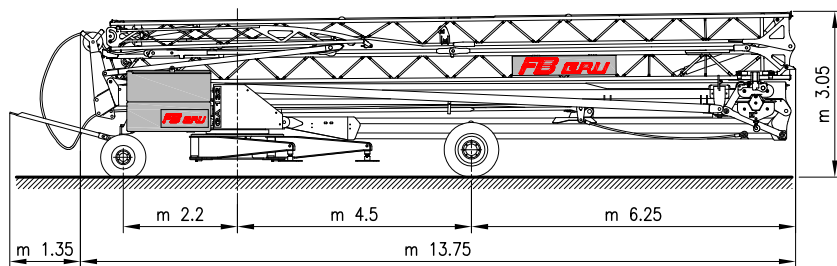

FB25K1

25
km/h

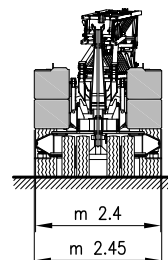
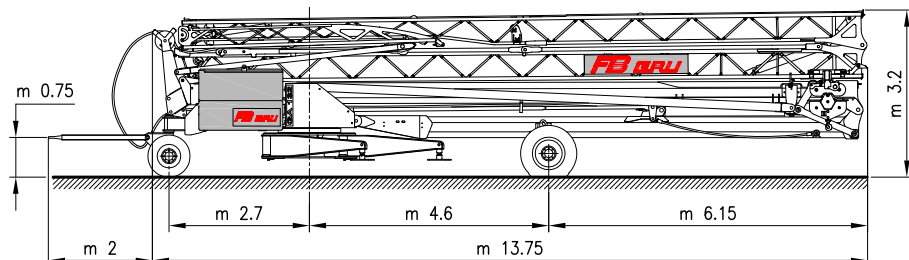

MONTAGGIO MONTAJE — ERECTION
MONTAGE — MONTAGE

